



**WASHINGTON STATE  
UNIVERSITY**

**Announcement of Opportunity  
For  
Food Service  
Compton Union Building (CUB)  
At  
Washington State University**

**AOO #052623**

**Washington State University Contact:**

**Karee Shaw (“AOO Coordinator”)  
Director, Facilities and Operations  
Washington State University  
1500 Glenn Terrell Mall  
Pullman, WA. 99164  
Tel: (509) 335-8711  
karee.shaw@wsu.edu**

## **1.0 Introduction**

### **Purpose of AOO**

The purpose of this Announcement of Opportunity (AOO) is to solicit proposals from qualified and experienced retail food vendors and to enter into a lease (the “Lease”) with the selected proposer to operate a retail food establishment in the first floor of the Compton Union Building (CUB) at Washington State University. Washington State University may hereafter be referred to as “WSU” or the “University”. WSU is examining several alternatives for providing this service and may decide, after reviewing proposals submitted, not to enter into any Lease.

### **Background**

WSU is a premier Tier 1 research university and the State of Washington’s land grant university. The University has a presence across the state and abroad, with five campuses (Pullman, Spokane, Tri-Cities, Vancouver, and Everett), four major research centers located throughout the state, and extension offices in every county, in addition to the Global Campus Online and international research. The flagship campus is located in Pullman, Washington, and serves approximately 17,000 undergraduate and graduate students, and employs approximately 5,900 faculty and staff.

### **Compton Union Building (CUB)**

The CUB is located in the heart of the Pullman campus and is the community center for the Pullman campus. The CUB provides opportunities and support for special events, meetings, student activities, and student administrative functions. The CUB underwent an \$86 million renovation in 2008, which positioned the CUB among the most premier student unions in the country and houses the Student Book Corporation (“The Bookie”) as the anchor tenant. The renovation also resulted in the CUB becoming the first building on WSU’s campus to be LEED certified. The CUB is located between the Holland Library on the pedestrian-intensive Glenn Terrell Mall and the WSU Football Stadium, at 1500 Terrell Mall, Pullman, Washington.

The CUB averages approximately 8,000 visits per day Monday through Friday during the academic year, with an average of 6,000 visitors coming between the hours of 11:00 AM and 4:00 PM. The CUB remains the largest and most utilized building on the WSU Pullman campus and houses the following operations:

- Six University departments
- Thirteen registered student organization offices and centers including Associated Students of Washington State University and Graduate Professional Student Association
- Services including Coug Prints Plus, CougarCard Center, Gesa Credit Union, US Bank, Washington State Employees Credit Union, and the Bookie
- Five retail food outlets, including Freshens, Carlita’s Mexican Grille, Cougar Country Subway, and Panda Express

## Goals and Objectives

The University's objective for this AOO is to provide the students, faculty, staff, and visitors with greater variety and a quality retail food option within the CUB. WSU is seeking vendors who will support the goals of the University and which will provide exceptional service, which includes, but is not limited to, the following functional requirements:

- Vendors who will, as a whole, provide a diverse menu of food alternatives at the CUB, giving visitors options on food type, price, and quantity.
- Flexibility to work in a facility that has multiple competitors in close proximity but understand that strong commitment to service and quality will benefit each individual vendor.
- Provide students with employment opportunities and potentially increase involvement with academic departments and learning opportunities for students.

## 2.0 AOO Details

The purpose of this section is to provide proposers with an understanding of the proposal process. This section contains instructions for proposers as they respond to this AOO and describes the various phases of screening, review, evaluation, and selection. It also explains the rights of the University in these procedures.

- 2.1 Proposal Response Outline. Proposals must be concise and in outline format. Pertinent supplemental information should be referenced and included as attachments. All proposals must be organized and tabbed to comply with the following sections:

*Tab A* LETTER OF TRANSMITTAL. The letter of transmittal should include an introduction of the proposer's company, the name, address, telephone number and fax number of the person to be contacted along with others who are authorized to represent the company in dealing with this AOO. Any other information not appropriately contained in the proposal itself should also be included in the letter.

*Tab B* EXECUTIVE SUMMARY. An executive summary will briefly describe the proposer's approach and clearly indicate any options or alternatives being proposed. It should also indicate any major requirements that cannot be met by the proposer.

*Tab C* DETAILED DISCUSSION. This section should constitute the major portion of the proposal and must contain **a specific response in outline form to each section in the Requirements Section of this AOO. Outline numbers should correspond, in order, to the section numbers contained in this AOO.** Failure to provide written response to items indicated in this AOO will be interpreted by the University as an *inability* by the proposer to provide the requested product, service, or function.

*Tab D* Pro Forma Cost. The proposer must submit operating costs and revenue projections for Five (5) years.

*Tab E* FINANCIAL REPORTS. The proposer should furnish a current financial report for the proposer's or its company's most recent fiscal year.

*Tab F* Miscellaneous additional information and attachments, if any, may be submitted by the proposer. Any proposal information that provides options or approaches for WSU to consider that may not be requested in this AOO should be provided in this area of the proposal.

- 2.2 Administrative Guidance. The information provided herein is intended to assist proposers in the preparation of proposals necessary to properly respond to this AOO. The AOO is designed to provide interested proposers with sufficient basic information to submit proposals meeting minimum requirements, but is not intended to limit a proposal's content or to exclude any relevant or essential data therefrom. Proposers are at liberty and are encouraged to expand upon the specifications to give additional evidence of their ability to provide the services requested in this AOO. WSU reserves the right to award additional points and/or consideration to proposers that present innovative, forward thinking, and creative solutions intended to ensure the success of their restaurant. Strategies that include locally sourced and WSU produced food or beverage ingredients are preferred and strongly encouraged.
- 2.3 Issuing office, AOO Reference Number, and Access to AOO. Management of the CUB is the issuing office for this AOO and all subsequent addenda relating to it. The reference number for the transaction is AOO#052623. This number must be referenced on all proposals, correspondence, and documentation relating to the AOO.
- 2.4 Due Date. **Proposals shall be submitted electronically via email to the AOO Coordinator identified on the cover page of this AOO by 5 p.m. Pacific Time on Friday, June 30, 2023.** Proposals received after this deadline will be late and ineligible for consideration. Following the deadline, the names of those responding to the AOO may be made available upon written request. All other information will remain confidential, to the extent allowed by law (please see section 7.7 herein).
- 2.5 Pre-Submittal Conferences. At a proposer's request, a pre-submittal conference may be scheduled with the AOO Coordinator to allow proposers to tour the CUB and the space(s) available under this AOO. All proposers responding to this AOO are encouraged to have at least one representative of their organization schedule a pre-submittal conference, but it is not required. **All pre-submittal conferences must be held between Monday, June 5 and Friday, June 23, 2023.**
- 2.6 Inquiries. Questions arising subsequent to the issuance of this AOO, that could have a significant impact on the responses to the AOO, should be submitted via email to the AOO Coordinator. Questions and answers will be consolidated and provided to all interested

parties via email from the AOO Coordinator. **All such questions should be received by Friday, June 23, 2023.**

2.7 Important Dates. The following dates are significant for this AOO:

AOO Dated and Issued: May 26, 2023

AOO Inquiry Questions Due: June 23, 2023

Pre-Submittal Conferences: between June 5, 2023 and June 23, 2023

AOO Due Date: June 30, 2023

2.8 Time for Evaluation. All submittals shall remain valid for a minimum of 180 calendar days after the AAO Due Date to allow adequate time for evaluation.

2.9 Evaluation of Submittals. The University may award the Lease based on initial submittals received without discussion of such submittals with proposers. Accordingly, each initial submittal should be submitted with the most favorable terms the proposer is able to offer.

2.10 Oral Presentation. The University may require an oral presentation by a proposer to supplement their written proposal. These presentations will be scheduled, if required, by the AOO Coordinator after submittals are received and prior to the award of the Lease.

2.11 Award of the Lease. Upon completion of the evaluation process, the University may award the Lease to the proposer whose proposal is determined to be most advantageous to the University. If a proposal is selected for award as a result of this AOO, WSU will contact the successful proposer in writing via email. Unsuccessful proposers will also be notified of the award decision via email. Only those at the University with delegated authority to do so are authorized to award a Lease for the proposed retail food operation and the services to be provided hereunder.

### **Scope of work – Specifications**

#### **3.0 Scope**

In this section, information will be provided about the CUB floor plans including the location of the food retail space currently available, core and shell building systems provided to that space, general information about the WSU-Pullman campus, and other CUB operational items that will affect proposers. General information of the maintenance, custodial, utilities, and other overhead expenses will be addressed in this section. This section will also provide context for the Lease with WSU.

3.1 First Floor Space. The first floor of the CUB includes a 5,315 square foot, 225-seat food service area, which is illustrated in the attached floor plan marked Appendix “A”. Current retail food vendors in this space include Panda Express, Subway, Carlita’s Mexican Grille, and Freshens. The Bookie Café, serving Starbucks coffee, grab and go food items and fresh

baked goods, is also located on the first floor of the CUB. The retail food space available on the first floor of the CUB contains approximately 750 square feet of kitchen/food service area and an allocation of approximately 1,544 square feet of the non-exclusive seating area, for a total of approximately 2,294 square feet. The first-floor space is illustrated by red outlining in Appendix "A". The University prefers that the successful proposer will be able to open for business in this first-floor space in the Fall of 2023.

A current list of all restricted or exclusive menu items and food types in the CUB is provided in Appendix "B" attached hereto. All proposers should review Appendix "B" before submitting a proposal to ensure that their proposed offerings will not be prohibited under the current restricted or exclusive uses.

3.1.1 Additional Spaces Available. The University may have additional retail food spaces available in the CUB, which range in size from approximately 770 square feet to 3,200 square feet. Proposers that may be interested in these additional spaces are encouraged to contact the AOO Coordinator for additional details.

3.2 General Information. The University will provide the building structure, exterior and interior wall systems, core and shell HVAC, plumbing, natural gas, electrical power, fire detection, fire sprinkler, and telecommunications infrastructure to the space. There is no existing furniture, fixtures and equipment located in the first floor space. The proposer will provide the design and decor for the space, and any furniture, fixtures and equipment necessary for its operation. The proposer will also provide all interior signage and menu boards for its operations, subject to University approval. Public recycling containers and trash receptacles within the space will be provided by the University. The proposer will need to coordinate its design with WSU Capital Planning and Development to ensure proposer's architectural concepts, design and specifications are in accordance with the design intent of the CUB and meets WSU requirements. WSU will review and approve the final improvement design submission from the proposer. The City of Pullman serves as the local authority having jurisdiction and will issue building and occupancy permits and provide building inspections associated with the building permit. The proposer will be required to seek and receive all other related licenses and permits necessary for operation, including but not limited to, Whitman County health permits associated with food service, alcohol permits as required by the Washington State Liquor Board (and subject to the University's prior approval), and permits required by the Washington State Department of Labor & Industry. The local agency for Whitman County food service-related permits is the WSU Environmental Health & Safety Office. The University reserves the right of prior approval of any subsequent change in plans for improvements, as well as any placement of signage and changes in decor, including colors and lighting within the space.

3.3 Vendor Name & Signage. The naming and signage of the vendor operation must be approved by the University, and the University reserves the right to reject any naming or signage that is not in the best interests of the University (as determined by the University).

- 3.4 Custodial/Maintenance. The successful proposer will be responsible for providing and paying for its own custodial services for the kitchen/serving area within the space, and University will supply successful proposer with custodial services for the non-exclusive seating area. The current rate for retail food vendors is \$2.32/GSF for custodial services per year. This also includes pest control for the vendor's kitchen and seating area. This sum is subject to annual increases and the final terms of the Lease will outline the methodology for annual increases.

The successful proposer will be responsible for the maintenance, repairs, and replacement of all of its kitchen equipment, grease ducts, and fixtures in its space. Vendor will be responsible for communicating any foreseeable issues or concerns to CUB maintenance staff upon discovery. CUB maintenance staff reserve the right to enter the space for the purposes of preventative maintenance and regular inspection. The proposer will be required to use WSU Maintenance Staff or WSU Facilities and Operations for all routine operations and maintenance work within the space, which includes, but is not limited to, electrical outlets, plumbing, and venting and kitchen facilities within the space. The proposer will need to contract with non-WSU staff to work on specialty equipment or fixtures supplied or ordered by the proposer. The proposer will be charged an hourly rate for Maintenance Services, which will be included in the Lease with the proposer.

- 3.5 Trash, Garbage, Recyclable Materials Services. WSU will provide garbage removal service from a central building dumpster. The proposer will be required to place daily accumulated trash in the dumpster. A recycling and compost area will also be available for each vendor at this location in the library garage. Vendor will be required to place selected recyclables in designated areas at the loading dock. The CUB will assess a fee, which is currently \$188.65 per month, for the trash removal and recycling services provided. This fee is subject to change on an annual basis.

The proposer will also be encouraged to have an effective waste management program to minimize garbage and maximize recycling to support the Waste Wise Recycling Program at WSU and WSU Executive Policy #24, found here: <https://policies.wsu.edu/prf/index/manuals/executive-policy-manual-contents/ep24-wsu-sustainability-initiative/>. The program should be site specific for the collection, recycling and disposal of the waste generated at the site. The program should include the procedures and processes to be used to separate, store and transport wastes and recyclables and compostable, and should also include methods to assure proper implementation of the plan. The proposer is encouraged to consult with the WSU Recycling & Sustainability Coordinator and Compton Union Administration to ensure the program realizes maximum results.

- 3.6 Utilities. Utilities in the space will be separately metered, to the extent possible, which will include phone and internet services. For those utilities that are not separately metered, the successful proposer will be responsible for reimbursing the University for its

proportionate share of such utilities. The successful proposer will be assessed a comparable rate (if they were located in a facility off-campus) for electrical and natural gas consumption. WSU will assess its external user rate for chilled water and steam consumption. Please see rates published by Avista utilities for electrical and natural gas consumption. Note, there is also an 8.2% handling charge for all utilities. Please see the City of Pullman’s rate matrix for water consumption. The annual average cost of utilities for the first-floor space is estimated at \$7,800 (based on Fiscal Year 2022 charges). This rate could vary greatly depending upon the successful proposer’s consumption of energy.

3.7 Card Technology/Point of Sale. At the present time, WSU uses a University ID card (CougarCard) for identification purposes that includes, for example, dining facility access, buildings and room access, access to the recreation center and athletic events, and library items for check out. The CougarCard also offers an account called Cougar CASH. Cougar CASH is a convenient, cashless way to pay at various locations on campus. It is a prepaid, stored-value account that is widely used by students, faculty, and staff to purchase items from vending machines, food vendors on campus and off-campus, the Bookie and some retail vendors.

It is expected that the successful proposer will accept Cougar CASH as a form of payment. The proposer is expected to purchase and install, at the proposer’s cost, all equipment necessary to accept these transactions.

3.8 Marketing / Advertising. The successful proposer will be responsible for all efforts and expenses related to marketing and/or advertising their services. The University intends to work with the proposer when possible to integrate/supplement proposer’s marketing efforts to assist in achieving the University’s vision for the restaurant.

3.9 Hours of Operation. Vendors may operate any hours the CUB is open, with a preferred closing at least 30 minutes prior to the CUB being closed. Since the University is on an academic calendar, the operating hours of the CUB vary from time to time. The CUB’s typical hours of operations are summarized as follows:

Number of Weeks/Year	Monday – Friday	Saturday & Sunday
32 Weeks (Academic)	7:30AM – 9:00PM	10:00AM – 9:00PM
16 Weeks (Summer)	7:30AM – 6:00PM	12:00PM – 5:00PM

There are roughly 4 weeks in the year where WSU is open for business, but general classes are not in session. The CUB sees a decline in visits and will work with a vendor on its desired hours. The CUB also closes its operations 8-10 days a year for designated holidays. Vendors will not be allowed to open on days when the CUB is closed. The CUB will endeavor to post these days at least six months in advance.

During closed hours, vendors may be granted access to their space at times mutually agreeable for the purposes of clean-up, maintenance, inventory, and preparation for



operation.

- 3.10 Security. Security of the CUB during closed hours will be the responsibility of the WSU Police Department. The proposer's space must be secured and locked when the proposer's space is closed. If the proposer has any special security requirements, they should be stated in their proposal. Security of the proposer's operations shall be the responsibility of the proposer.
- 3.11 Equal Opportunity and Sexual Harassment Policies. All proposers must agree to comply with all existing federal, state, and local laws prohibiting discrimination or sexual harassment. Proposers must also agree to abide by policies concerning these matters as set forth by Washington State University.
- 3.12 Tobacco use. Sale or use of any tobacco products in the CUB and the University's campus is strictly prohibited.
- 3.13 Drug Free Work Place. Washington State University is a drug free workplace and all proposers must comply with the drug free policy that Washington State University has established.
- 3.14 Coca-Cola Beverages. The successful proposer will be restricted to serving only Coca-Cola beverages and/or other brand names owned, controlled or licensed by the Coca-Cola Company, as defined by and in compliance with the exclusive Beverage Sponsorship and Pouring Rights Agreement, as amended (the "Sponsorship Agreement") dated August 1, 2000 by and between University and Coca-Cola, during the existence of such Sponsorship Agreement or any subsequent sponsorship agreement. University shall advise the apparent successful bidder of the specific list of approved beverages and permitted exceptions prior to opening for business.

#### **4.0 Requirements – Qualifications Evaluation**

Minimum Mandatory Requirements. The mandatory screening performed in Section 4 is a preliminary evaluation designed to ascertain the proposers' ability to meet minimum standards required to effectively function in the Washington State University environment. The screening results are pass or fail. A passing evaluation will allow a proposer to continue along the evaluation path. Any failing evaluation will result in proposer disqualification. Proposers will be immediately notified if they receive a failing evaluation during this phase of consideration.

- 4.1 Experience. Proposers should provide evidence of experience of successfully operating and managing all aspects of a retail food service operation. The University is interested in a proposer who can successfully market their service to bring in enough customers to make the operation a commercial success over the long term to reduce vendor turnover and provide continuity of services. Proposers should provide locations of existing food services which can be visited by the evaluation committee to assess the appearance of

the operation and where samples of proposer's proposed food and beverage items can be obtained. Proposers should provide a brief history of their business(es), its operations, the number of years in business, and any other pertinent information regarding the ability to successfully operate the vendor space.

4.1.1 The University prefers that the successful proposer has had a functioning retail food operation for at least the past five (5) years (continuous). Describe your company's retail food and beverage experience.

4.2 Food Type / Menu. Proposers' food offerings will be evaluated in terms of the attractiveness, pricing and quality of the menus proposed, and the University is interested in innovative menus that could include any number of different types of food offerings. Variety is encouraged. Proposers must provide a sample of the menu they propose to offer and which should identify which items are intended to be provided on a daily basis versus items that are "specials." Menus must include approximate pricing information for each item. The University is open to proposals which include a rotating menu. This specification is intended not to "lock in" the final menu, but to give WSU an idea of what to expect in terms of the food type, pricing and quality that will be provided. In accordance with Section 5, the University may require that finalists demonstrate the quality and presentation of their food items; which if required will be arranged separately between the University and the proposers.

4.2.1 Perceived Quality/Value. To achieve the University's mission, the University desires a high level of quality when compared to the price. Proposers will ultimately set both the quality level and the final prices. The University may evaluate the quality and value of the proposed food offerings through site visits to proposer's existing food services operations and evaluations of the proposed menu pricing. Provide a summary of the estimated prices for the food and beverage offerings.

4.2.2 Provide the general nutritional content of the food prepared for consumers. Proposers will also be evaluated on whether they can demonstrate that organic foods or ingredients are used in their products. Proposers that use locally sourced food products, ingredients and beverages, particularly from the University, will be given higher preference during the University's evaluation process.

4.3 Financial Structure. The University is seeking a proposer who can support its own business enterprise, using the University-owned space, to create a "free-standing" operation that does not require additional University funds or subsidization from the University. The Base Rent for the first-floor space will be a minimum of \$3,500.00/month ("NNN"), which will periodically increase over the term of the Lease. The University may be willing to consider a revenue-sharing plan in which the University is provided with a percentage of gross sales revenue over a minimum agreed upon Base Rent amount. Any proposals requiring the University to cover any up front and/or additional operational

expenses (beyond those which are explicitly granted in this AOO), or that will potentially provide the University with less than the minimum amount above, will be heavily penalized in the final proposal evaluation process. Any other proposed financial arrangements for the final Lease between the University and the successful proposer shall be provided as an optional proposal in Tab F and shall be considered only at the sole discretion of the University.

**The provisions of the state of Washington’s Leasehold Excise Tax (“LET”) as set forth in RCW 82.29A will apply to the Lease. LET is a tax on fair market value rent for the act or privilege of occupying or using publicly owned real or personal property through a leasehold interest. The LET rate is subject to change and is presently assessed at the rate of 12.84%. LET will be calculated on the Base Rent amounts for the applicable period multiplied by the then rate. LET payments will be remitted to University at the same time and in the same manner as its payment of Base Rent.**

4.4 **References.** Identify the three (3) references you feel represent the best relationships with your company by ranking them 1, 2 or 3. At least *one* reference for an existing operation in which the proposer provides services similar to those required by the University is to be provided. Include business name, address, phone number and contact person for each reference. The University reserves the right to contact or visit any of the proposer’s current and/or past operations to evaluate the level of performance and customer satisfaction.

4.5 **Commitment to Community Development and Growth and Sustainable Practices.** Please provide a summary of how the proposer would benefit the University and the surrounding area. Include information on whether local products, particularly locally grown agricultural products, or labor will be used in the proposer’s service. Local is defined as products grown and processed in the Northwest with an emphasis on a 200 mile radius of the Pullman campus. Proposers should also demonstrate how they utilize environmentally sound practices in their retail food and beverage operations. This may include use of recycled materials, or environmentally friendly cleaning or service products. Proposers should describe how the services and products provided by the proposer will align with the strategic goals of Washington State University, and specifically, Executive Policy #24.

## **5.0 Evaluation Process.**

All proposals in response to this AOO will be evaluated in a manner consistent with all applicable State of Washington and University rules and policies.

In the initial phase of the proposal evaluation process, the evaluation committee will review all proposals timely received. First, nonresponsive proposals (those not conforming to AOO requirements) will be eliminated. Second, the remaining proposals will be evaluated in a cursory manner to eliminate from further consideration those

proposals, which in the judgement of the evaluation committee, fail to offer sufficient and substantive provisions to warrant further consideration. Each proposer bears sole responsibility for the items included or not included in the response submitted by that proposer. The University reserves the right to disqualify any proposal that includes significant deviations or exceptions to the terms, conditions and/or specifications in this AOO.

At the conclusion of this initial evaluation phase, finalist proposals will be selected for detailed review and evaluation, including oral presentations if required. The University may also require that finalists demonstrate the quality and presentation of their food items; which if required will be arranged separately between the University and the proposers. The University reserves the right to be the sole judge as to the overall acceptability of any proposal or to judge the individual merits of specific provisions within competing offers.

All responsive proposals shall be evaluated and scored based on the following criteria:

Quality of the response and providing all requested information. (Pass / Fail)

Quality, experience, and reputation of the responder and any current or past operations; which includes reference information as applicable. (40 points)

Meeting the objectives as stated in this AOO including but not limited to: use of local food and beverage ingredients, willingness to work with the University on initiatives stated herein, providing a concept that fits well into the WSU and Pullman community, and other perceived value provided in a response that positions the operations for success. (40 points)

Financial considerations including but not limited to: the financial standing of the responder and proposed financial arrangements in the proposal. (20 points)

The University reserves the right to add points for any innovative or creative approaches not necessarily detailed herein.

NOTE: The evaluators may adjust their scoring during the various stages of evaluation of this AOO as they learn more about each proposer and their respective proposal.

## **6.0 Cost Proposal**

Final costs and the structure of the Lease shall be negotiated with the apparent successful proposer. In the event that the University cannot come to agreeable terms and conditions with the apparent successful proposer, it may then negotiate with the next highest scoring proposer or may make no award as a result of this AOO.

## 7.0 General Terms and Conditions

In submitting a proposal in response to this AOO, the proposer agrees to accept the following terms set forth in this AOO:

- 7.1 Lease Terms and Conditions: The apparent successful proposer will be expected to enter into a Lease with terms and conditions that are consistent with those required by the State of Washington and the University as a state public institution of higher education. If the University and the apparent successful proposer are unable to come to agreement on the structure, terms, and conditions of a mutually acceptable Lease, the University reserves the right to begin negotiations with the next highest scoring responder or to cancel this AOO without making an award. The responders are requested to submit a Certifications and Assurances form attached as Exhibit "A". The University will review any terms or conditions provided in a proposer's response or during Lease negotiations and accept or reject the same at its sole discretion.
- 7.2 Most Favorable Terms: The University reserves the right to make an award without further discussion of the proposals submitted. Therefore, the proposal should be submitted initially on the most favorable terms which the proposer can propose. The University reserves the right to utilize a best and final offer procedure if it is determined to be in the University's best interest, however, proposers should respond with their most favorable terms that the proposer can honor if it is chosen as the successful proposer. The University also reserves the right to contact a proposer for clarification of its response. The apparent successful proposer should be prepared to accept this AOO for incorporation into a Lease resulting from this AOO. Lease negotiations may incorporate some or all of the proposer's response within the University's discretion. Proposer should not propose any terms in its proposal that it is not willing to incorporate into the Lease. It is understood that the response and the terms proposed by proposer will become a part of the official competition file on this matter without obligation to the University.
- 7.3 Responsiveness: All proposals will be reviewed by the AOO Coordinator to determine compliance with administrative requirements and instructions specified in this AOO. The proposer is specifically notified that failure to comply with any part of the AOO may result in rejection of the response as non-responsive. WSU also reserves the right at its sole discretion to waive minor administrative irregularities.
- 7.4 Costs to Propose: The University will not be liable for any costs incurred by the proposer in preparation of a proposal submitted in response to this AOO, in conduct of a presentation, or any other activities related to responding to this AOO.
- 7.5 Contracting with Current or Former State Employees: Specific restrictions apply to contracting with current or former state employees pursuant to chapter 42.52 of the Revised Code of Washington. Proposers should familiarize themselves with the

requirements prior to submitting a response that includes current or former state employees.

- 7.6 Minority & Women-Owned Business Participation: In accordance with chapter 39.19 RCW, the State of Washington encourages participation in all of its contracts by firms certified by the Office of Minority and Women's Business Enterprises (OMWBE). Participation may be either on a direct basis in response to this solicitation or on a subcontractor basis. However, no preference will be included in the evaluation of responses, no minimum level of MWBE participation shall be required as a condition for receiving an award and responses will not be rejected or considered non-responsive on that basis.
- 7.7 Proprietary Information/Public Disclosure: Proposals submitted in response to this AOO shall become the property of the University. All proposals received shall remain confidential until the Lease, if any, resulting from this AOO is signed by the University, and the apparent successful proposer; thereafter, the responses shall be deemed public records as defined in Chapter 42.56 of the Revised Code of Washington (RCW). Any information in the proposal that the proposer desires to claim as proprietary and exempt from disclosure under the provisions of Chapter 42.56 RCW, or other state or federal law that provides for the nondisclosure of your document, must be clearly designated. The information must be clearly identified and the particular exemption from disclosure upon which the proposer is making the claim must be cited. Each page containing the information claimed to be exempt from disclosure must be clearly identified by the words "Proprietary Information" printed on the lower right-hand corner of the page. Marking the entire response exempt from disclosure or as Proprietary Information will not be honored. If a public records request is made for the information that the proposer has marked as "Proprietary Information," the University will notify the proposer of the request and of the date that the records will be released to the requester unless the proposer obtains a court order enjoining that disclosure. If the proposer fails to obtain the court order enjoining disclosure, the University will release the requested information on the date specified. If a proposer obtains a court order from a court of competent jurisdiction enjoining disclosure pursuant to Chapter 42.56 RCW, or other state or federal law that provides for nondisclosure, the University shall maintain the confidentiality of the proposer's information per the court order.
- 7.8 No Obligation to Contract: This AOO does not obligate the State of Washington or the University to enter into a Lease or contract for services specified herein.
- 7.9 Rejection of Responses: The University reserves the right at its sole discretion to reject any and all proposals received without penalty and not to issue a Lease as a result of this AOO.
- 7.10 Commitment of Funds: The President of the University or his delegates are the only individuals who may legally commit the University to the expenditures of funds for a Lease

resulting from this AOO. No cost chargeable to the proposed Lease may be incurred before receipt of a fully executed Lease.

- 7.11 Evaluation Procedure: Responsive proposals will be evaluated strictly in accordance with the requirements stated in this AOO and any addenda issued. The evaluation of proposals shall be accomplished by an evaluation team(s), to be designated by the University, which will determine the apparent successful proposal. The University, at its sole discretion, may elect to select the top-scoring proposers as finalists for an oral presentation. The AOO Coordinator may contact the proposer for clarification of any portion of the proposer's response. The University reserves the right to award the Lease to the proposer whose proposal is deemed to be in the best interest of the University and the State of Washington.
- 7.12 Notification to Proposers: The University will notify the apparent successful proposer of its selection in writing via email upon completion of the evaluation process. Individuals or firms whose responses were not selected for further negotiation or award will be notified separately by e-mail or facsimile.
- 7.13 Debriefing: Proposers with unsuccessful proposals may, within five (5) days of receipt of notification, request a meeting for debriefing and discussion of their proposals. The request must be in writing and addressed to the AOO Coordinator at the following address:

Karee Shaw  
Director, Facilities and Operations  
Washington State University  
1500 Glenn Terrell Mall  
Pullman, WA 99164  
Tel: (509) 335-8711  
karee.shaw@wsu.edu

Comparisons between proposals, or evaluations of other proposals, will not be allowed at the debriefing conference. The University will only respond to questions regarding a proposer's proposal.

Appendixes and Exhibits Attached:

- Appendix "A" – Floor Plan  
Appendix "B" – Current List of Restricted or Exclusive Menu Items and Food Types  
Exhibit "A" – Certifications and Assurances

**Appendix "A"**

**Floor Plan**

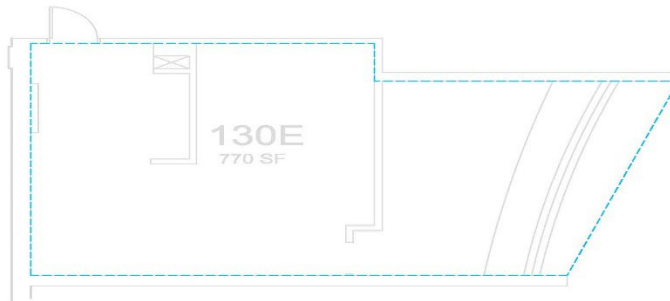
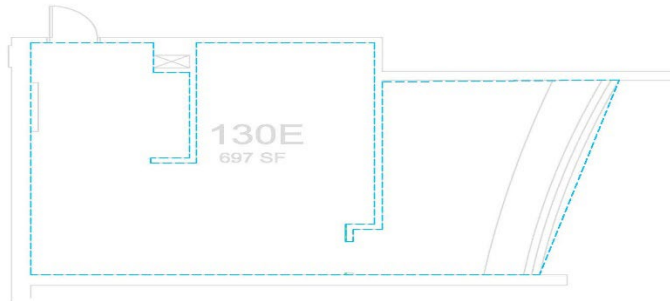
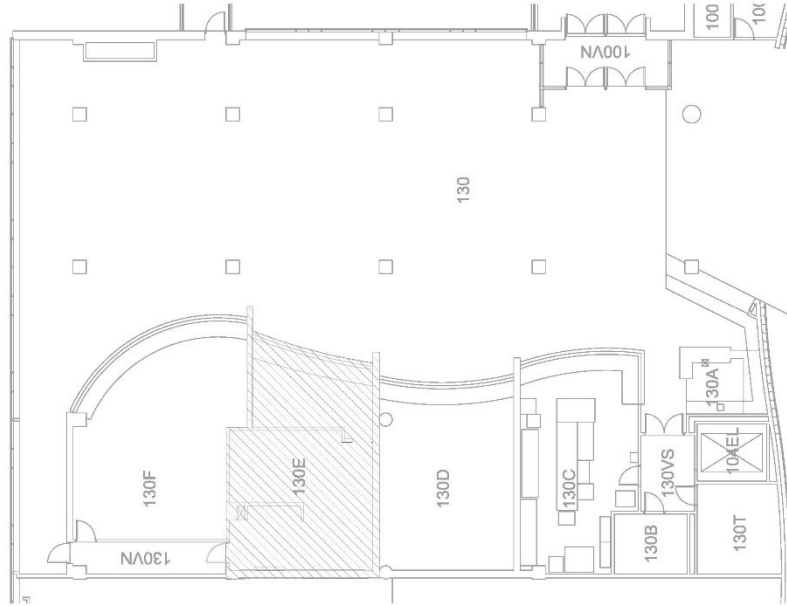



## **Appendix "B"**

### **Current List of Restricted or Exclusive Menu Items and Food Types** (items that cannot be sold in the CUB or considered under this AOO)

- All beverage products other than Coca-Cola beverages and/or other brand names owned, controlled or licensed by the Coca-Cola Company, as defined by and in compliance with the Sponsorship Agreement referenced in this AOO
- Sushi
- Incidental Asian food (Chinese, Japanese, Vietnamese, Thai, Hawaiian, and Korean)
- Fresh, made to order sandwiches and wraps

## Exhibit "A"

### **Certifications and Assurances (to be included in your proposal)**

I/we make the following certifications and assurances as a required element of the proposal to which it is attached, understanding that the truthfulness of the facts affirmed here and the continuing compliance with these requirements are conditions precedent to the award or continuation of the related contract:

1. I/we declare that all answers and statements made in the proposal are true and correct.
2. The prices and/or cost data, **if any**, have been determined independently, without consultation, communication, or agreement with others for the purpose of restricting competition. However, I/we may freely join with other persons or organizations for the purpose of presenting a single proposal.
3. The attached proposal is a firm offer and will remain valid until \_\_\_\_\_, **20\_\_** and it may be accepted by the University without further negotiation (except where obviously required by lack of certainty in key terms) at any time prior to \_\_\_\_\_, **PM**.
4. In preparing this proposal, I/we have not been assisted by any current or former employee of the State of Washington whose duties relate (or did relate) to this proposal or prospective contract, and who was assisting in other than his or her official, public capacity. If there are exceptions to these assurances, I/we have described them in full detail on a separate page attached to this document.
5. I/we understand that the University will not reimburse me/us for any costs incurred in the preparation of this proposal. All proposals become the property of the University, and I/we claim no proprietary right to the ideas, writings, items, or samples, unless so stated in this proposal.
6. Unless otherwise required by law, the prices and/or cost data, **if any**, which have been submitted have not been knowingly disclosed by the Proposer and will not knowingly be disclosed by him/her prior to opening, directly or indirectly, to any other Proposer or to any competitor.
7. I/we agree that submission of the attached proposal constitutes acceptance of the solicitation contents. If there are any exceptions to these terms, I/we have described those exceptions in detail on a **page attached to this document labeled Exhibit A.1**.
8. No attempt has been made or will be made by the Proposer to induce any other person or firm to submit or not to submit a proposal for the purpose of restricting competition.
9. I/we grant the University the right to contact references and other, who may have pertinent information regarding the ability of the Respondent and the lead staff person to perform the services contemplated by this AOO.
10. If any staff member(s) who will perform work on this contract has retired from the State of Washington under the provisions of the 2008 Early Retirement Factors legislation, his/her name(s) is noted on a separately attached page.

11. Washington Wage Law Certification: Prior to awarding a contract, institutions of higher education in the State of Washington are required to determine that a bidder is a “responsible bidder.” See RCW 39.26.160(2) & (4). Pursuant to legislative enactment in 2017, the responsible bidder criteria include a Applicant certification that the Applicant has not willfully violated Washington’s wage laws. I/we hereby certify, under penalty of perjury under the laws of the State of Washington, that I/we are not currently debarred from doing business with the State of Washington. **INITIAL ONE:**

\_\_\_\_\_ NO WAGE VIOLATIONS. I/We have NOT been determined by a final and binding citation and notice of assessment issued by the Washington Department of Labor and Industries or through a civil judgment entered by a court of limited or general jurisdiction to have willfully violated, as defined in RCW 49.48.082 any provision of RCW chapters 49.46, 48.48, or 49.52 within three (3) years prior to the date of signing this Certifications & Assurances Form below.

OR

\_\_\_\_\_ VIOLATIONS OF WAGE LAWS. I/We have been determined by a final and binding citation and notice of assessment issued by the Washington Department of Labor and Industries or through a civil judgment entered by a court of limited or general jurisdiction to have willfully violated, as defined in RCW 49.48.082, a provision of RCW chapters 49.46, 49.48, or 49.52 within three (3) years prior to the date of the above-referenced procurement solicitation date.

**ON BEHALF OF THE RESPONDENT SUBMITTING THIS PROPOSAL, MY NAME BELOW ATTESTS TO THE ACCURACY OF THE ABOVE STATEMENTS.**

_____ SIGNATURE	_____ TITLE	_____ PRINT NAME
_____ EMAIL ADDRESS	_____ TELEPHONE	_____ DATE